



Ghostscript Status

OpenPrinting summit April 2011

Michael Vrhel, Ph.D.
Artifex Software Inc.
San Rafael CA



Ghostscript overview

What is new and what is coming...

Color architecture

Halftoning

Open issues:

- X11alpha

- Patterns and transparency

- Cups color spaces



The Basics

Ghostscript is a document conversion and rendering engine.

Written in C ANSI 1989 standard (ANS X3.159-1989)

Essential component of the Linux printing pipeline.

Dual GPL/Proprietary licensed. Artifex owns the copyright.

Source and documentation available at www.ghostscript.com

Graphical Overview

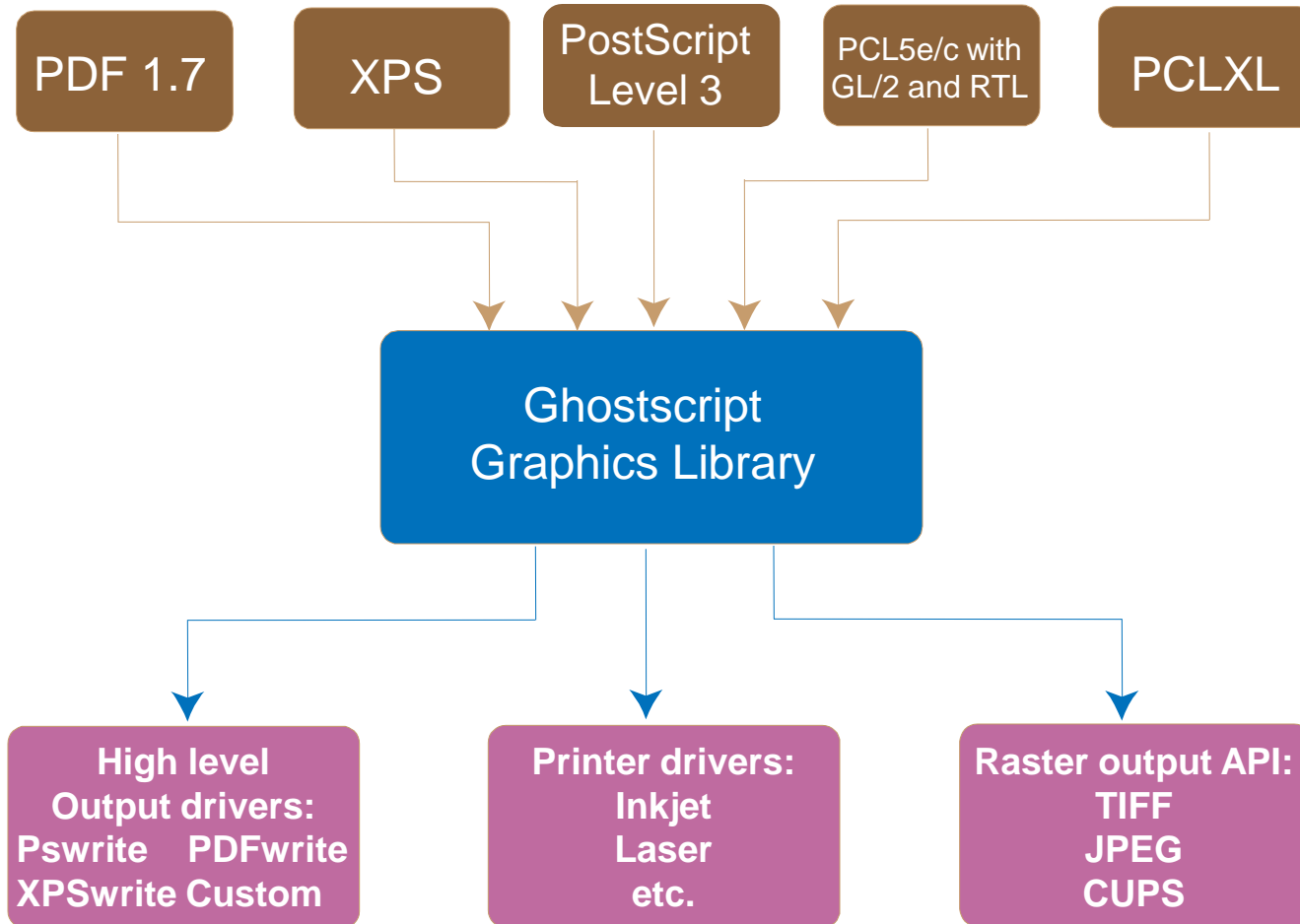

Understanding devices is a major key to understanding ghostscript.

Devices can have high-level functionality. e.g. pdfwrite can handle text, images, patterns, shading, fills, strokes and transparency directly.

Devices may be set up to handle only certain high-level operations.

Graphics library has “default” operations. e.g. text turns into bitmaps, images decomposed into rectangles.

In embedded environments, calls into hardware can be made.

Raster devices require the graphics library to do all the rendering.



Relevant Changes to GS since last meeting....

New ICC color management added (9.0)

Free type font rendering as default and new font engine API (9.0)

Fixes for several issues with CUPs color spaces (9.01)

High speed halftoning using SSE2 commands. (9.02)



Upcoming Changes to GS (release 9.03*)

Support for anti-aliasing when source contains transparency (in trunk, testing)

Support for littleCMS 2.1 (in trunk, testing)

Object based color rendering (development started)

Support for output rendering intent (development started)

Support for proofing profiles, device link profiles and profile override (hopefully)

Ghostscript is moving to git....

Ghostscript Color Flow

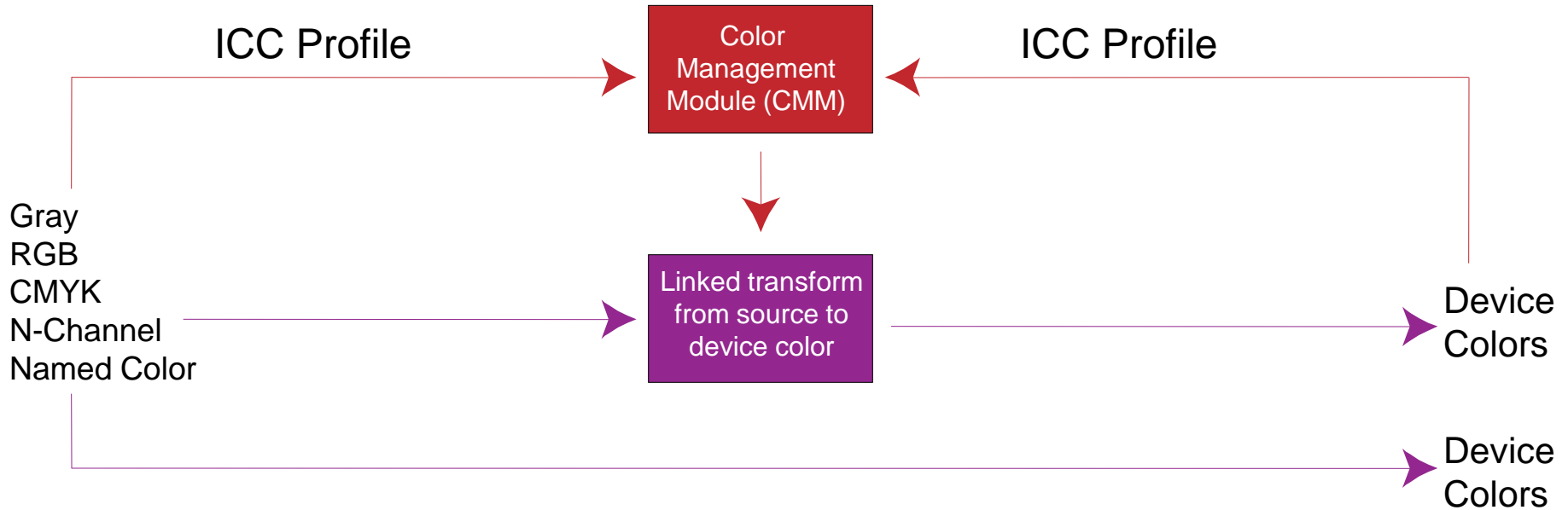

Ghostscript Color Architecture

- Easy to interface different CMM with Ghostscript.
- ALL color spaces defined in terms of ICC profiles.
- Linked transformations and internally generated profiles cached.
- Easily accessed manager for ICC profiles.
- Devices communicate their ICC profiles and have their ICC profile set.
- Operates efficiently in a multithreaded environment.
- Handles named colors with ICC named color profile or proprietary format.
- Color management of Device-N colors.
- Includes object type (e.g. image, graphic, text) and rendering intent into the computation of the linked transform (upcoming)
- Proofing, profile override and device link profiles. (upcoming)

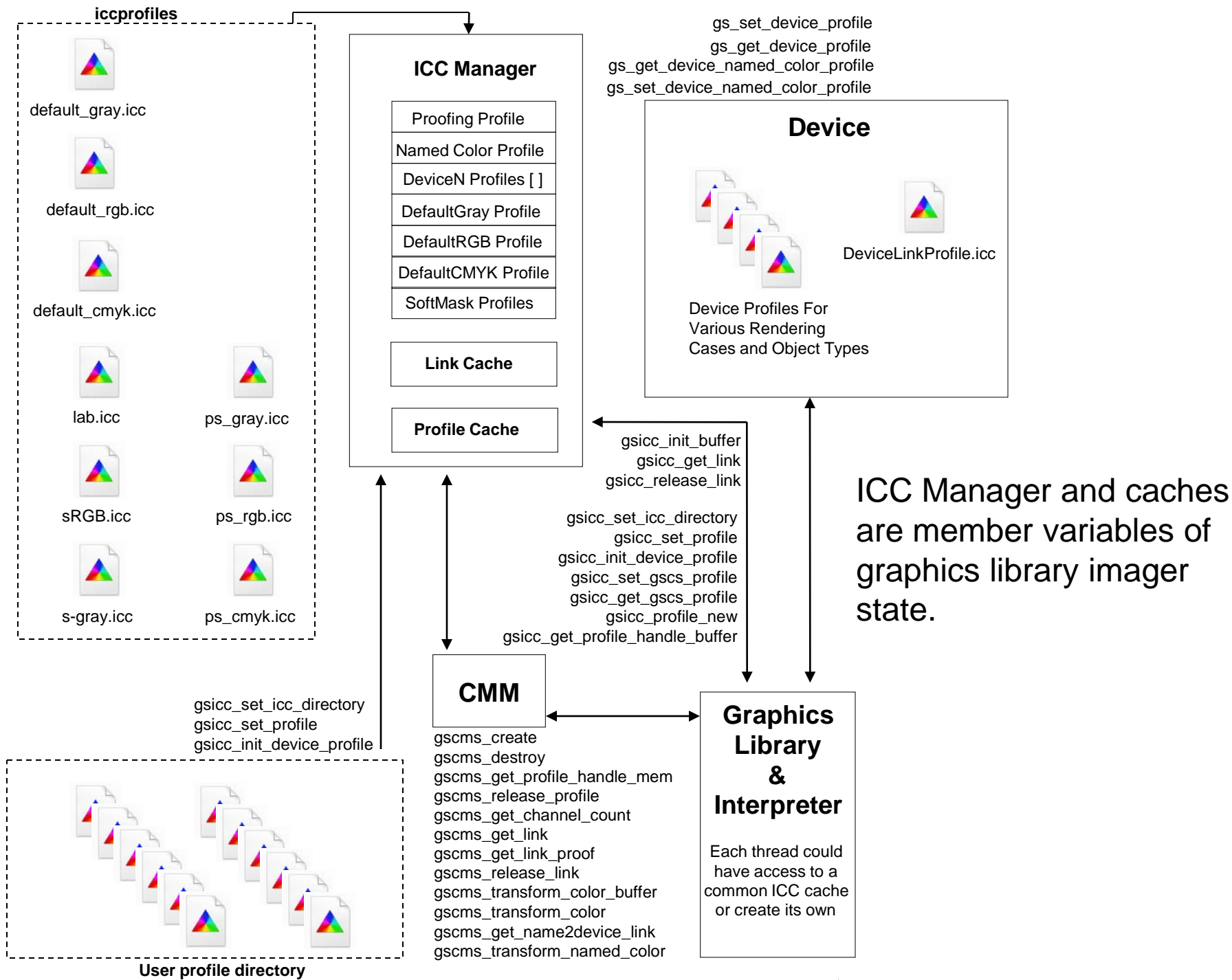

Link Cache

GRAPHICS LIBRARY

```
gsicc_get_link(* pis, *input_colorspace, *output_colorspace, *rendering_params,
memory, include_softproof)
```

Link Cache

Hash Code	Ref Count	Link Structure
Hash Code	Ref Count	Link Structure
Hash Code	Ref Count	Link Structure
Hash Code	Ref Count	Link Structure
.	.	.
.	.	.
.	.	.
.	.	.
Hash Code	Ref Count	Link Structure

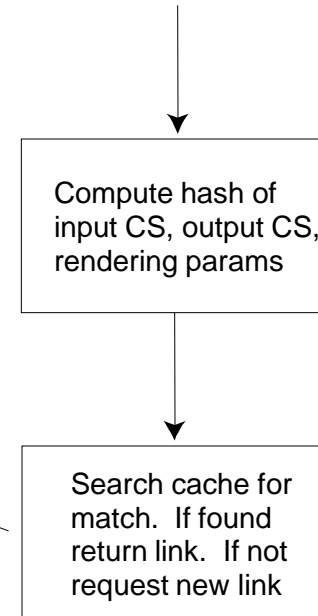

Link entries are reference counted.

Links are only released if we are at maximum number (or memory), new request is made and a Ref Count is one.

Conversion of PS and PDF Color Spaces

- PS and PDF CIE color spaces are converted to ICC forms that the CMM can handle.
- PS mappings are all 1-way. Device to CIEXYZ or CIEXYZ to Device.
- Procedural mappings are sampled.
- Because of the multiple matrix operations and procedural mappings, some PS color spaces that do not include MLUTs will give rise to ICC profiles that do include MLUTs.

Example PS CIEABC

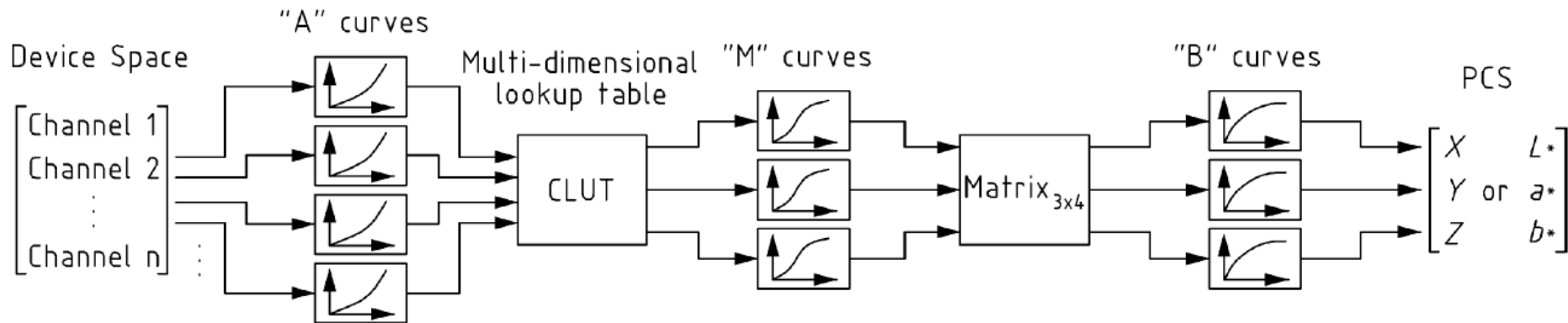
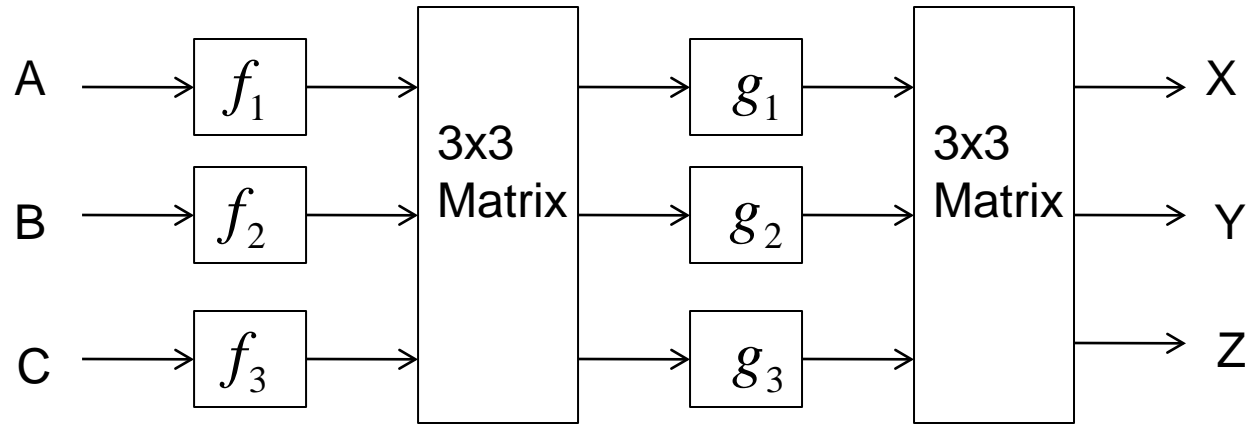

Profile Cache

- Ghostscript creates ICC profiles from PDF and PS CIE colorspace definitions (e.g. CalRGB, CIEABC, CIEDEFG)
- To avoid repeated creations, these profiles are cached based upon a hash code that is related to the resource ID.
- Cache is designed such that MRU item is at the top of the list.
- Profiles are only released if we are at maximum number (or memory), new request is made and a reference count is one.

Device N color spaces (PDF and PS)

- For Device N output, very simple to provide capability for N-color ICC profile.
- Many desire to have CM with CMYK and to pass additional spot colors unmolested.
- For DeviceN input color, XPS requires ICC profile. PDF and PS use an alternate tint transform.
- Architecture provides capability to define N-color ICC profile for DeviceN input colors to replace the alternate tint transform if desired.



CMM API

Get Profile Operations

```
gcmhprofile_t gscms_get_profile_handle_mem(unsigned char *buffer,  
                                           unsigned int input_size);
```

```
gcmhprofile_t gscms_get_profile_handle_file(const char *filename);
```

Get Link Operations

```
gcmmlink_t gscms_get_link(gcmmlinkprofile_t lcms_srhandle,  
                          gcmmlinkprofile_t lcms_deshandle,  
                          gsicc_rendering_param_t *rendering_params);
```

```
gcmmlink_t gscms_get_link_proof(gcmmlinkprofile_t lcms_srhandle,  
                                gcmmlinkprofile_t lcms_deshandle,  
                                gcmmlinkprofile_t lcms_proofhandle,  
                                gsicc_rendering_param_t *rendering_params);
```

```
gcmmlink_t gscms_get_name2device_link(gcmmlinkprofile_t lcms_srhandle,  
                                       gcmmlinkprofile_t lcms_deshandle,  
                                       gcmmlinkprofile_t lcms_proofhandle,  
                                       gsicc_rendering_param_t *rendering_params)
```



CMM API

Information Operations

```
int gscms_get_channel_count(gcmmhprofile_t profile);
```

```
gsicc_colorbuffer_t gscms_get_profile_data_space(gcmmhprofile_t profile);
```

```
int gscms_get_pcs_channel_count(gcmmhprofile_t profile);
```

```
char* gscms_get_clrtname(gcmmhprofile_t profile, int colorcount);
```

```
int gscms_get_numberclrtnames(gcmmhprofile_t profile);
```



CMM API

Overhead and Cleanup Operations

```
void gscms_create(void **contextptr);
```

```
void gscms_destroy(void **contextptr);
```

```
void gscms_release_link(gsicc_link_t *icclink);
```

```
void gscms_release_profile(gcmmhprofile_t *profile);
```

Current Color Command Line Interface

Source Default Profiles

-sDefaultGrayProfile = my_gray_profile.icc
-sDefaultRGBProfile = my_rgb_profile.icc
-sDefaultCMYKProfile = my_cmyk_profile.icc
-sDeviceNProfile = my_devicen.icc

Device Profile

-sOutputICCPProfile = my_device_profile.icc

ICC Search Directory

-sICCPProfilesDir = c:/my_iccprofiles/

Other Settings

-sNamedProfile = my_namedcolor_profile.icc

Color Commands line options to come.....

Device Profile(s)

-sOutputTextProfile = my_device_text_profile.icc
-sOutputGraphicProfile = my_device_graphic_profile.icc
-sOutputImageProfile = my_device_image_profile.icc

-sTextRenderIntent = colorimetric
-sGraphicRenderIntent = saturation
-sImageRenderIntent = perceptual

Other Settings

-sProofProfile = my_proof_profile.icc
-sDeviceLinkProfile = my_link_profile.icc
-dIgnoreEmbeddedProfiles



Halftoning

Recent inclusion of high speed halftoning with an 8 bit threshold array.

Makes use of SSE2 128bit registers to operate on 16 pixels at a time.

Current support in trunk is for monochrome output devices only.

For release 9.03 we should have in place support for high speed halftoning for CMYK planar devices.

<http://bugs.ghostscript.com/>

Bugzilla – Main Page version 3.4.5

Home | New | Search | | Reports | Preferences | Administration
| Log out michael.vrhel@artifex.com

Welcome to Bugzilla



[File a Bug](#)



[Search](#)



[User Preferences](#)

[Quick Search help](#) | [Install the Quick Search plugin](#)

[Bugzilla User's Guide](#) | [Release Notes](#)

Home | New | Search | | Reports | Preferences | Administration
| Log out michael.vrhel@artifex.com

[My Bugs](#) | [All Mine](#) | [Everything](#) | [My Closed](#) | [My Customer Bugs](#)
customer bugs

X11alpha (default device on Linux) and Cups Device Issues

For cups device there remain a few color open color issues related to RGBW color space (Bug 691922). Confusion about what W is....

A handful of X11alpha bugs that are actively being looked at and are likely all caused by the same issue.

Transparency Pattern Color Spaces From CarioGraphics. Speed issue. (Bug 691755)



A comment on PDF output rendering intent

Discussions on OpenICC list about ghostscript NOT supporting the output intent. (Bug 691952)

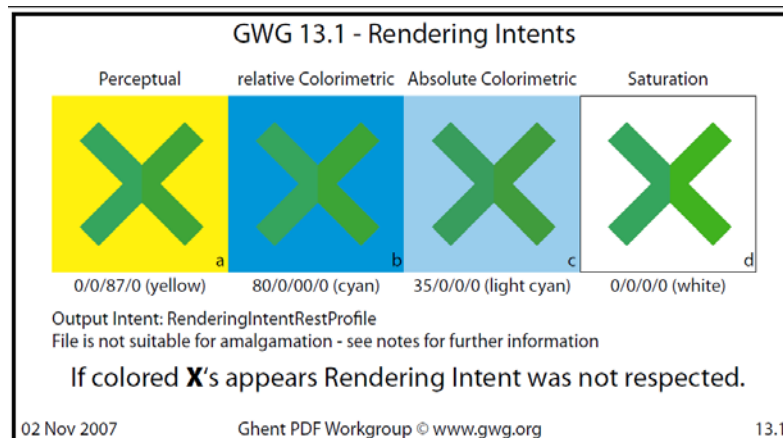
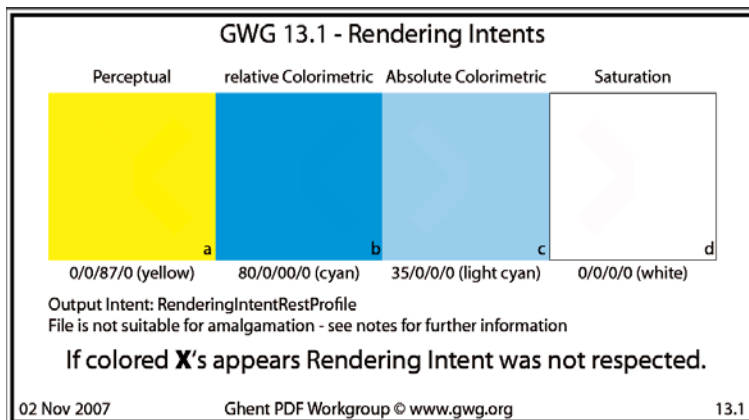

OutputIntents array (Optional; PDF 1.4) An array of output intent dictionaries describing the color characteristics of output devices on which the document might be rendered (see “Output Intents” on page 970).

Need to understand the case of multiple output intents – which one is used?

Likely will add a `-dUseOutputIntent` command line option.



Thank you for your attention!



michael.vrhel (at) artifex.com